

Certified according to DIN EN ISO 9001

## Technical Datasheet



## ZHM Series Gear Flow Meter

Applications .....	3
Principle and Design .....	3
Special Requirements .....	4
K-Factor & Linearity .....	4
Gear Flow Meters for Paints .....	5
Technical Data .....	6
Dimensional Drawings .....	7
Pressure Drop .....	9

# Index

Index

## Application

Gear Flow Meters are suitable for the precise flow measurement of various fluids of viscosities from 5 up to 25,000 mm<sup>2</sup>/s. Providing sufficient lubricity of the fluid, the small Gear Flow Meters type ZHM 01/1 and 02 as well as ball bearing versions may also be used for fluids below 5 mm<sup>2</sup>/s.

For such applications special specifications apply for the low flow range and linearity. Generally our Turbine Flow Meters, type HM, and Micro Flow Meter, type LFM 10, will handle low-viscosity fluids perfectly.

## Principle and Design

Gear Flow Meters are positive displacement meters, similar in design to a gear pump. The measuring medium rotates two gears, which are engaged with minimum play.

The medium is forced along through closed measuring chambers between gears and housing. The gears, which run idle, lose no power.

## Pickups and Amplifiers

The RPM of the gears is in proportion with the instantaneous flow rate and is precisely detected by integral pickups through the body of the meter without contacting the fluid. Pulses per volume unit will finally serve the evaluation.

- VTE\*/P carrier-frequency amplifier with single pickup
- VTM local display unit with integral frequency- and analogue output
- TD carrier-frequency amplifier with twin pickup
- VTQ quadruple carrier-frequency pickup and amplifier with integral divider
- FOP fibre-optical amplifier for electrostatic environment
- IF\*/VIEG inductive pickup and amplifier

Details on pickups are available in separate datasheets.

## Typical Applications

- Waterborne paints, clear coatings, 2-component paints, highly-filled metal paints and softfeel paints
- Coating wax, glues, PVC, epoxy resin, highly-filled and abrasive fluids
- Polyol- and isocyanate
- Oil, fat (also food and cosmetics)
- Hydraulic oil
- Off-shore-applications, special meters with high-pressure connectors up to 690 bar

## Specials

- Very high output frequency
- Short response time
- High pressure up to 690 bar
- Reverse flow detection and puls multiplication
- Ex-protected EExialICT4 or T6 for zone 1
- Applicable in electrostatic spraying systems

## Special Requirements

### Dynamic measurements

The output frequency of gear flow meters is very high resulting in very good resolution and suitability for pulsating flow rates.

### Reverse-flow detection and pulse multiplication

Fitting a twin pickup, reverse flow can be detected. Furthermore, pulse rates can be multiplied for faster and more accurate evaluation.

### Ex-protection

Ex-protected EExialICT6/T4 pickups and amplifiers are available for zone 1, zone 0 subject to individual inspection. In addition, intrinsically-safe supply units may be provided.

### Resistance to high voltage from 50 kV up to 120 kV

Fibre-optical pickups (type FOP) are available for electrostatical painting systems.

### KEM evaluation electronics for monitoring, control and 2-component application

FAU frequency to analogue converter • MCM 400 display • MCM 200 evaluation system (also with printer)



## K-Factor and Linearity

The K-Factor (no. of pulses per litre) is almost constant over a wide range. Even with low flow rates measuring results are very precise as leakage is kept down to a minimum by very close production tolerances. A linearity error of  $\pm 0.5\%$  of instant value can be easily maintained for a flow ratio of 1:20 and viscosities above  $15 \text{ mm}^2/\text{s}$ . Accuracy improves as viscosity increases. The linearity error will decrease to  $\pm 0.25\%$  of instant flow for viscosities from 50 to over  $10,000 \text{ mm}^2/\text{s}$ .

The individual K-factor and linearity for each ZHM is determined during calibration and documented for the user in calibration records. When calibrating we consider as much as possible operating viscosities and customer's specifications.

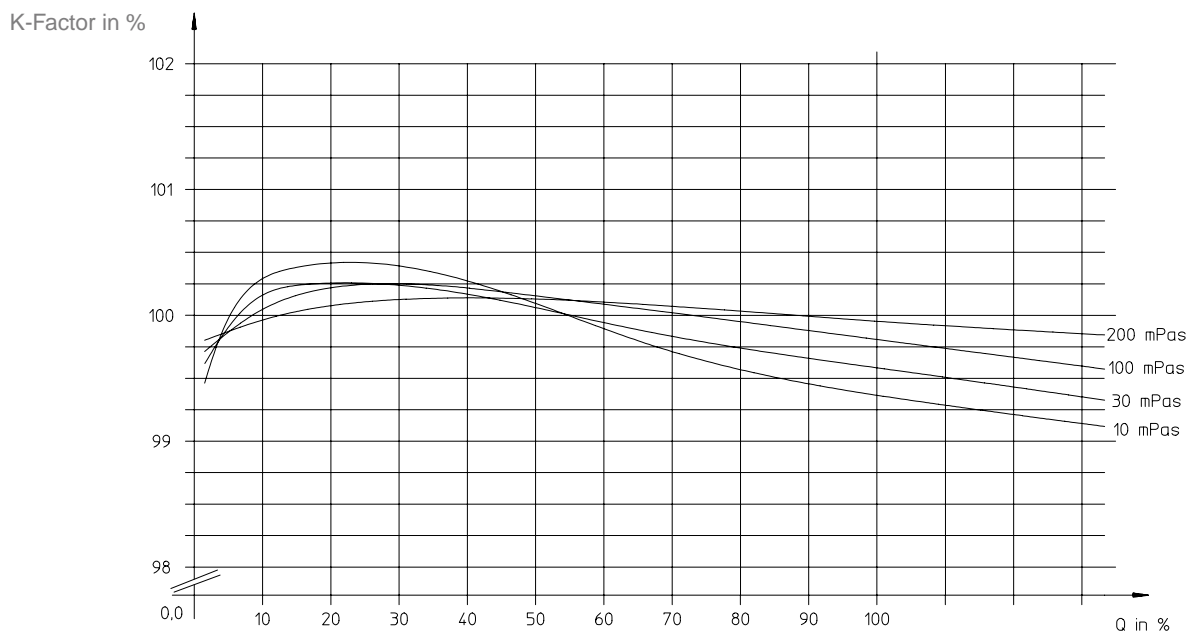

## Gear Flow Meters for Paints

Rapid colour changes and low solvent consumption are the major quality requirements with state-of-the-art paint-spraying systems. The flow meter as part of the system must contribute to meet these requirements. The meter has to be of a low weight to enable an installation close to the spray gun, and it must facilitate complete purging within a few seconds.

We designed our light-weight meter type ZHM 02/1 LW to meet these particular requirements. The weight was reduced by 50% compared with standard ZHM 02/1 and dead space was eliminated by patented construction features. The new design found the approval of most major automotive companies in world wide applications in paint-spraying systems.



### ZHM...CT.FM. - A further development of lightweight flow meters

The new ZHM...CT.FM series continues the development of paint flow meters combining the characteristics of the lightweight series and new cartridge design as well as an improved measuring kit. The cartridge design reduces the total weight of the flow meter down to a mere 550g.

Thanks to this reduction the ZHM...CT.FM may be installed right behind the spray gun without adverse effects on the dynamic properties and positioning accuracy of the spray robot. The newly designed measuring kit provides a high resolution and allows for a precise measurement over a measuring range which would usually require two flow meters.

### Application Area

The ZHM...CT.FM is suitable to handle base paints, fillers, transparent and waterborne coatings perfectly. As a major advantage over other measuring systems the fibre-optic signal transmission from the ZHM...CT.FM allows for the use in electrostatic spraying systems.

A separate datasheet on the ZHM...CT.FM series is available on request.

## Technical Data

Type	Meas.range, ltr/min		K-Factor, pulses/ltr <sup>2</sup> )		Frequency range Hz	
			single pickup	twin pickup	single pickup	
ZHM 01	0.005	to 1	41,000	82,000	3.4	to 683
ZHM 01/1 <sup>1)</sup>	0.005	to 2	26,500	53,000	2.2	to 883
ZHM 01/2 <sup>1)</sup>	0.02	to 3	14,000	28,000	4.6	to 700
ZHM 02/1 <sup>1)</sup>	0.05	to 2	8,200	16,400	6.8	to 273
ZHM 02 <sup>1)</sup>	0.1	to 7	4,200	8,400	7	to 490
ZHM 03	0.5	to 25	1,740	3,480	14	to 725
ZHM 04	0.5	to 70	475	950	4	to 554
ZHM 05	5	to 150	134	268	11	to 335
ZHM 06/1	5	to 250	106	212	8.8	to 442
ZHM 06	20	to 500	53	106	18	to 442
ZHM 07	50	to 1,000	24	48	20	to 400

Specifications apply when using amplifier type VTE\*/P and for viscosities from 30 mm<sup>2</sup>/s onwards.

1) Also available as weight-reduced version for paints (cf. page 5)

2) Average values, individual K-factors can be taken from calibration records supplied with each ZHM

## Connections and Nominal Pressure

Type	Connections	max. pressure
ZHM 01 bis ZHM 03	female threads for Ermeto-fittings GE 6-PSM	PN 630 bar
ZHM 04	female threads for Ermeto-fittings GE 14-PSM	PN 630 bar
ZHM 05	female threads for Ermeto-fittings GE 25-PSM	PN 400 bar
ZHM 06/1, 06	bores for SAE flanges 1 ¼", PSI 6000	PN 400 bar
ZHM 07, 07 KL	bores for SAE flanges 1 ½", PSI 6000	PN 400 bar

Ermeto fittings, SAE connectors and higher pressure rates available on request.

## Materials

housings: ..... standard: stainless steel as per DIN 1.4305 / AISI 303  
 ..... special: DIN 1.4404 / AISI 316 L or 1.4571 / AISI 316 Ti  
 gears: ..... standard: stainless steel as per DIN 1.4122 / AISI 303  
 ..... special: DIN 1.4460 / AISI 329  
 shafts, bearing bushes: ..... tungsten carbide, ball bearings on request  
 seals: ..... O-rings: Viton, NBR, EPDM (for break fluids) or Teflon

**Dimensional Drawings (mm)**

**ZHM 01 to ZHM 05**

*Side view*

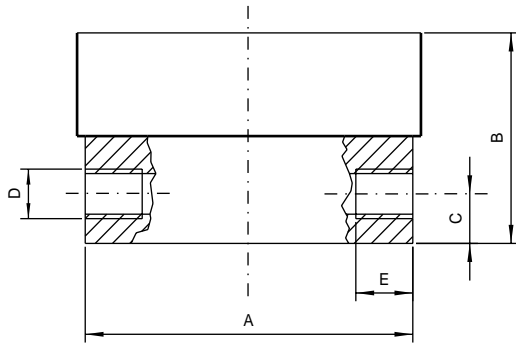

metric threads

Type	A	B	C	D	E
ZHM 01	72.0	41	10.5	M12 x 1.5	14
ZHM 01/1	72.0	41	10.5	M12 x 1.5	14
ZHM 01/2	72.0	50	10.5	M12 x 1.5	14
ZHM 02/1	80.5	51	12.0	M12 x 1.5	14
ZHM 02	80.5	55	12.0	M12 x 1.5	14
ZHM 03	80.5	67	12.0	M12 x 1.5	14
ZHM 04	121.0	96	17.0	M20 x 1.5	18
ZHM 05	170.0	133	22.5	M33 x 2.0	18

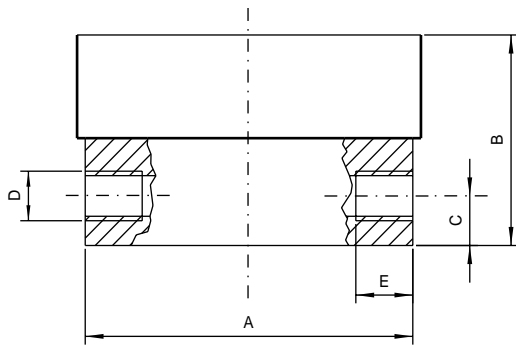

inch threads

Type	A	B	C	D	E
ZHM 01	72.0	41	10.5	G 1/4"	14
ZHM 01/1	72.0	41	12.0	G 1/4"	14
ZHM 01/2	72.0	50	12.0	G 1/4"	14
ZHM 02/1	80.5	51	12.0	G 1/4"	14
ZHM 02	80.5	55	12.0	G 1/4"	14
ZHM 03	80.5	67	12.0	G 3/8"	14
ZHM 04	121.0	96	17.0	G 1/2"	18

*Bottom view*

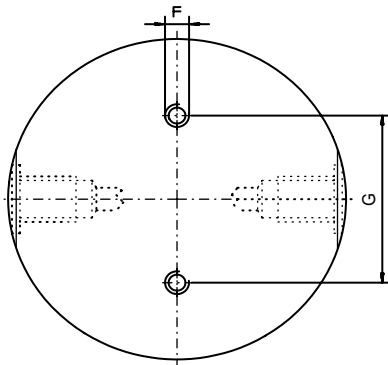

Type	F	G
ZHM 01	M6	44
ZHM 01/1	M6	44
ZHM 01/2	M6	44
ZHM 02/1	M6	44
ZHM 02	M6	44
ZHM 03	M6	44
ZHM 04	M6	60
ZHM 05	M8	100

## Dimensional drawings (mm)

### ZHM 06 to ZHM 07

Side view

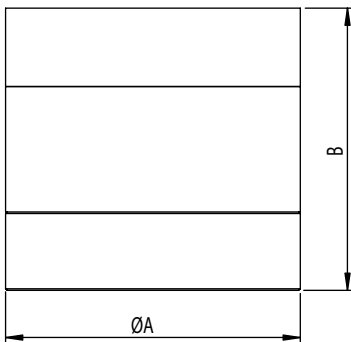

Type	$\varnothing A$	B
ZHM 06/1 KL	188	138
ZHM 06 KL	188	180
ZHM 06	188	180
ZHM 07 KL	232	200
ZHM 07	232	200

Bottom view ZHM 06

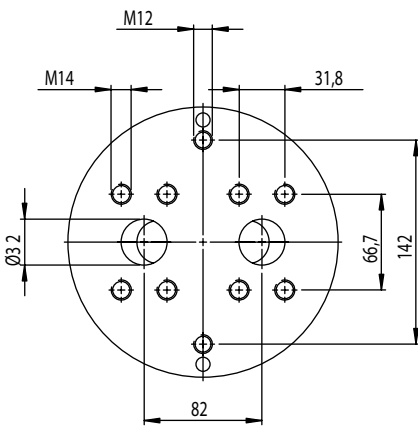

Bottom view ZHM 07

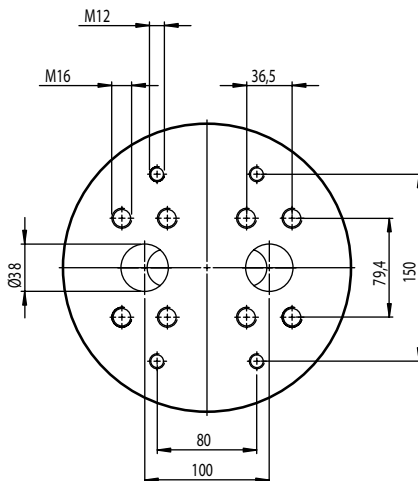



Pressure Drop

ZHM 01 to ZHM 02 - Pressure drop in bar

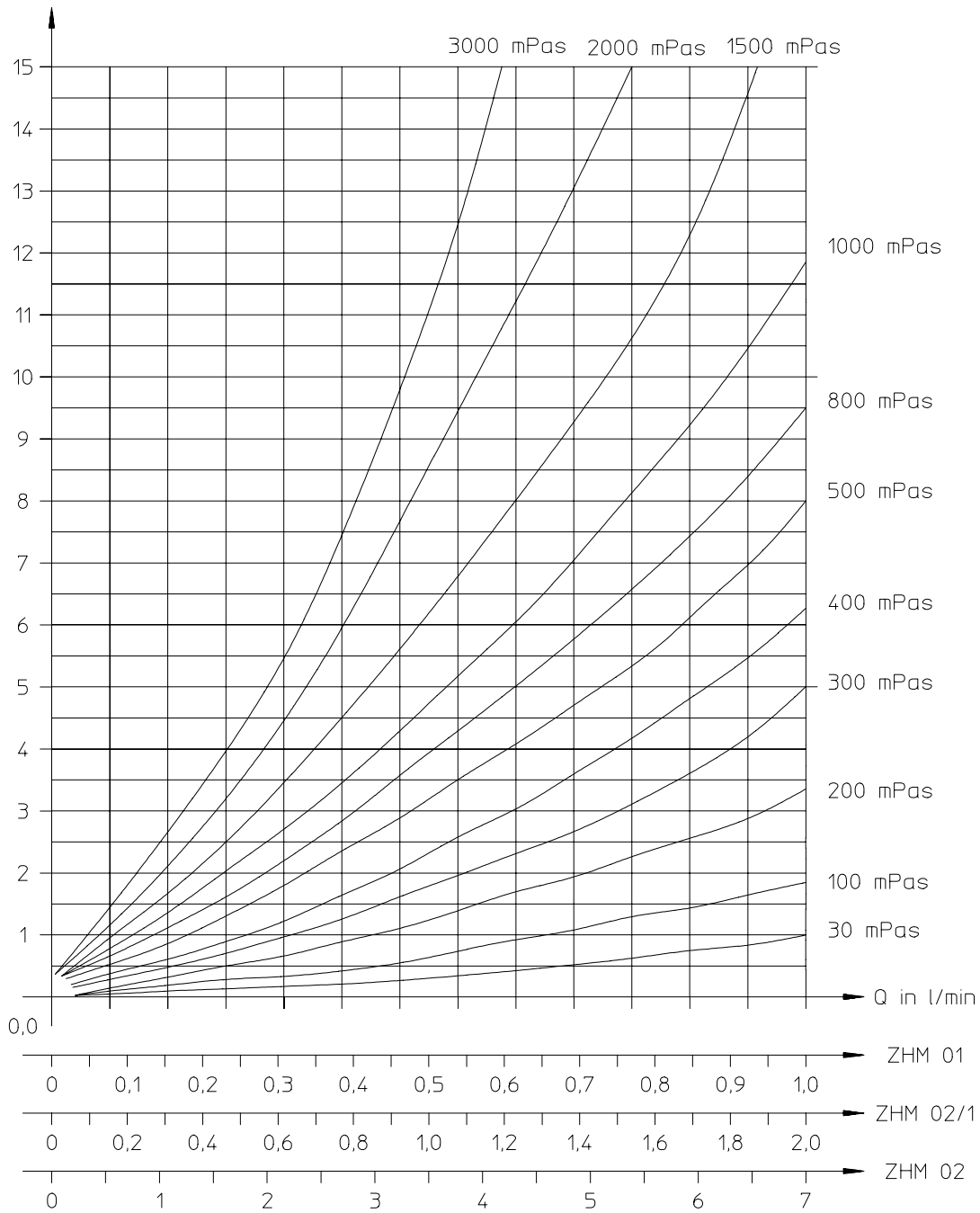

**Pressure Drop**

ZHM 03 to ZHM 05 - pressure drop in bar

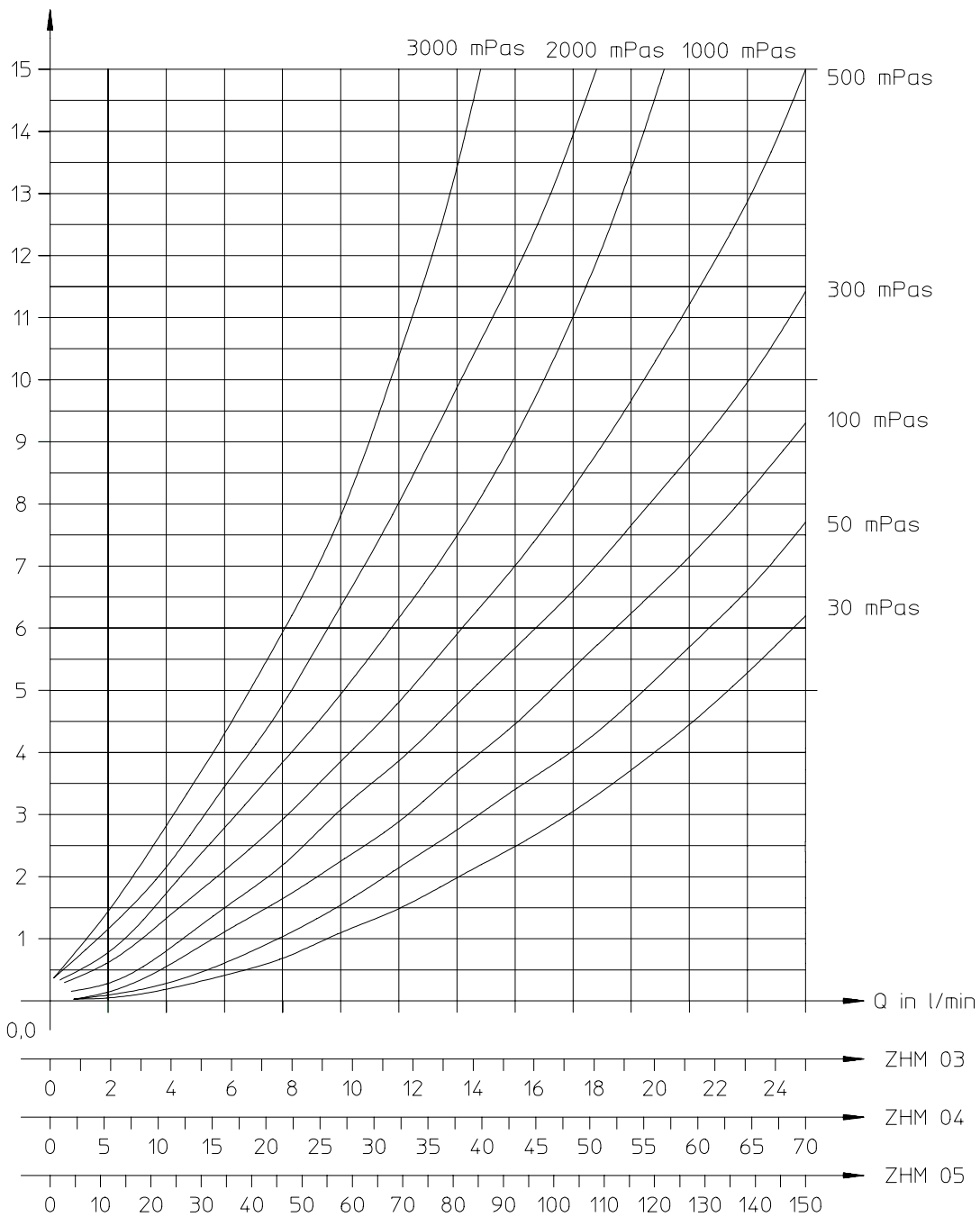

### Pressure Drop

ZHM 06/1 KL to ZHM 06 KL - pressure drop in bar

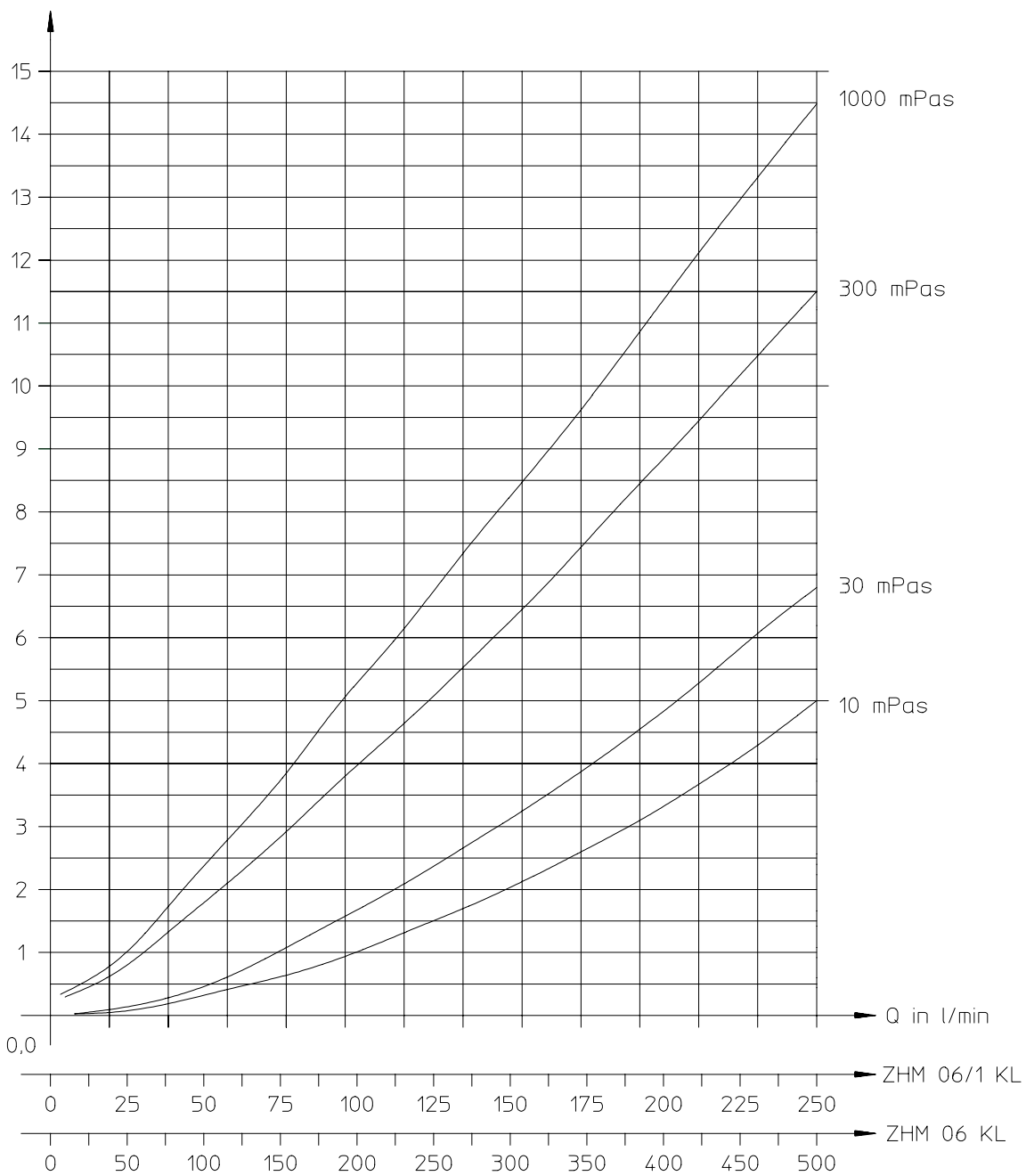

Pressure Drop

ZHM 06 to bis ZHM 07 - pressure drop in bar

